



SOUTHWEST**SOLUTIONS**GROUP

business organization systems

ROTARY

STORAGE SYSTEMS

SECURE WORK MATERIALS STORAGE



MAXIMUM SPACE EFFICIENCY

Spacesaver Rotary storage allows you to store more in less space and better organize parts, tools and supplies at the point-of-use. Rotary storage units rotate, providing easy access to back-to-back storage compartments. When not in use, files can be locked in closed positions, presenting a clean, uncluttered appearance.

BENEFITS

- Increase your organizational efficiency and productivity.
- Space-efficient and cost-effective storage alternative.
- Place storage closer to point-of-use to streamline process and reduce hunting.
- Better organize tools, parts and supplies in a centralized storage.
- Provide extra measure of security for stored supplies.
- Keep tools, parts and supplies from being lost or damaged.
- System design allows storage flexibility to meet your needs.

ACCESSIBILITY

Shared access from either side.

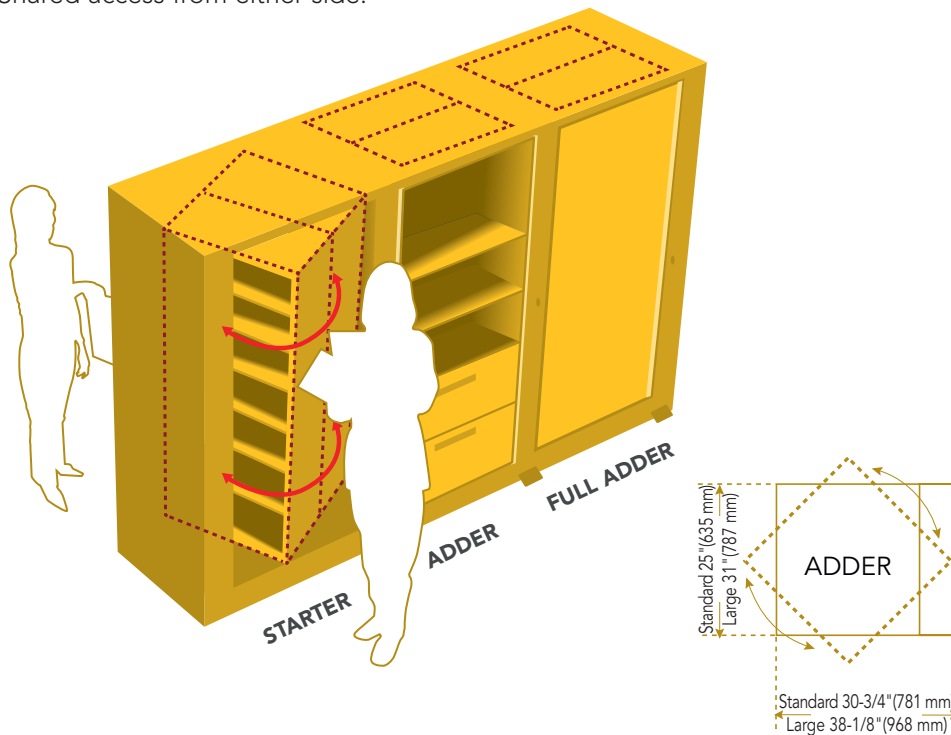

STARTER

The first cabinet in any row of Spacesaver Rotary Storage units is always a Starter. This unit can stand alone, or Adder units can be connected to either side.

FULL ADDER

Where active supplies demand increased accessibility, a Full Adder allows the freedom of simultaneous access to adjoining units. Connected to a Starter, the Full Adder provides its own rotation space.

ADDER

Sharing rotation space with their neighbors, Adder units reduce the necessary floor space of a Starter by six (6) inches in width. The number of Rotary Storage units that can be connected together is limited only by the physical constraints of your space plan.

OPTIONS



Bins Storage

Keep tools and supplies organized and accessible to find. Optional dividers create compartments and flexibility.



Laminate Work Surfaces

Can be utilized as a workstation, providing a convenient way to review materials on the spot.



Security Drawers

For restricted access to confidential information or maintaining privacy Security Drawers are the answer.



Interior Drawers & Shelves

Vertically adjustable increments of 1-3/4" (44 mm), permitting a wide variety of custom configurations.



Drawer Dividers



Durable Powder Paint Coated, 20-Gauge Steel

Available in 32 colors.

Drawer Guides

Sturdy roll-out ball-bearing guides, providing smooth motion and ease-of-use.



Secure Drawer Latches

Corrosion-resistant zinc plated torsion springs, keep drawers securely closed when not in use.



Closed Position

Shared access from either side.

Non-slip Pedal Design

To rotate, simply depress the foot pedal and gently push. Automatically stops in the next position – either fully opened or fully closed.



Roll-Out Reference Shelves

Optional roll-out reference shelves serve as handy work surfaces providing an easy way to review materials on the spot.



Touch Pad Release

A waist-high, electronic keypad control, provides an extra measure of security.



Key Lock

To provide secure storage for sensitive supplies.

SPECIFICATIONS

Rotary unit widths, depths and weight capacities are shown below. Units are available in 12 tier heights. As needs change, the system can be easily reconfigured.

Max. Weight Capacity Per Shelf: Standard - 60 lbs.
Large - 75 lbs.

Max. Weight Capacity Per Rotary Unit: Standard - 1080 lbs.
Large - 1350 lbs.

STARTERS AND ADDERS

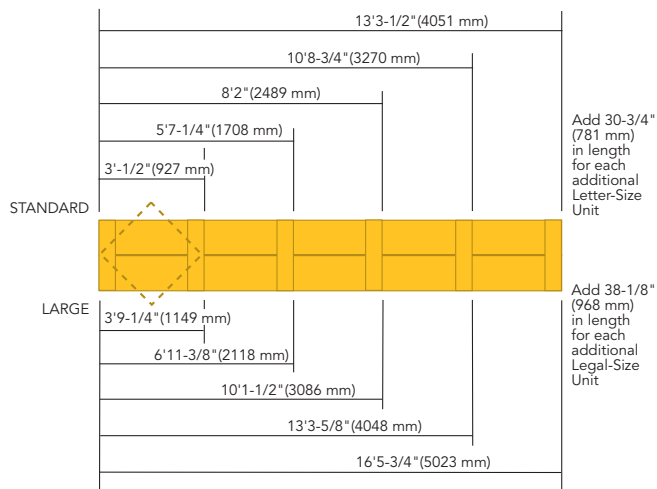

STARTERS AND FULL ADDERS

