

INSTALLATION INSTRUCTIONS

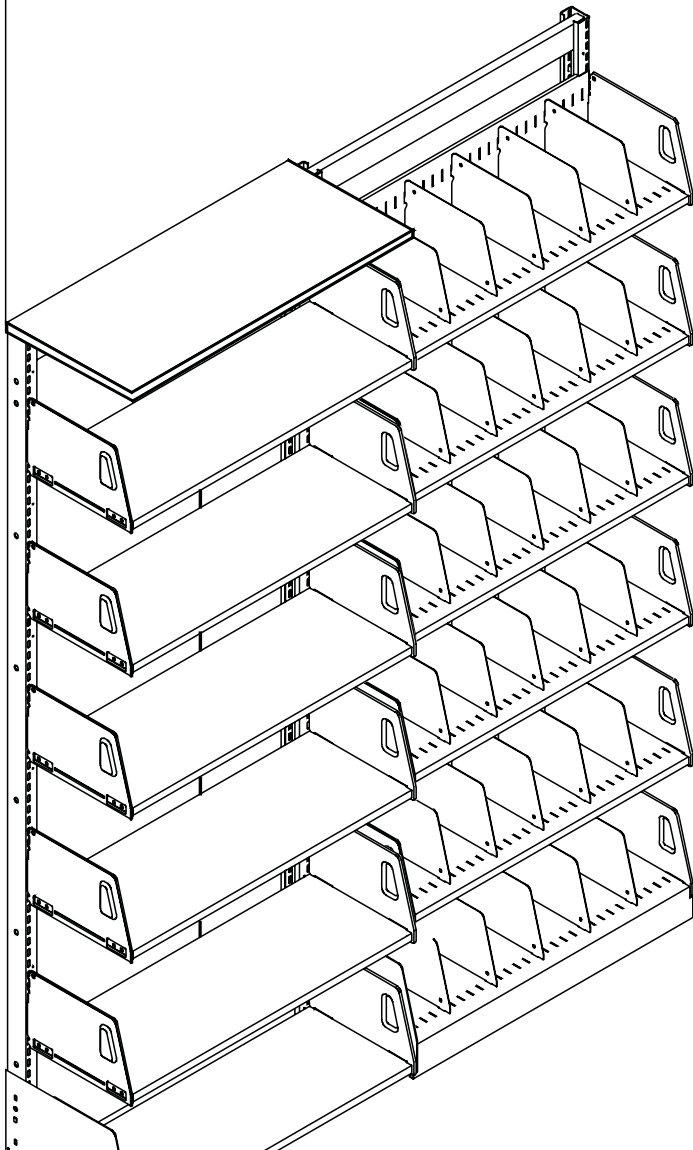

SOUTHWEST **SOLUTIONS** GROUP

business organization systems



LIBRARY SHELVING

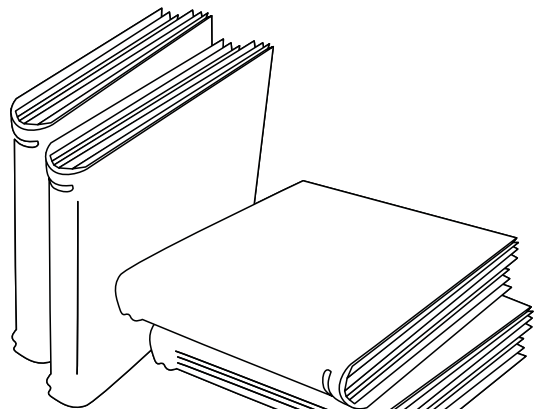

Major Components Identification	
Mobile	2
Static	3
Hardware Identification	4
Pre-Installation	5
Installation	
Single Face Mobile Units	6
Double Face Mobile Units	8
Single Face Static Units	10
Double Face Static Units	12
Adjustable Shelves	14
Base Shelves	16

Major Components Identification / Mobile

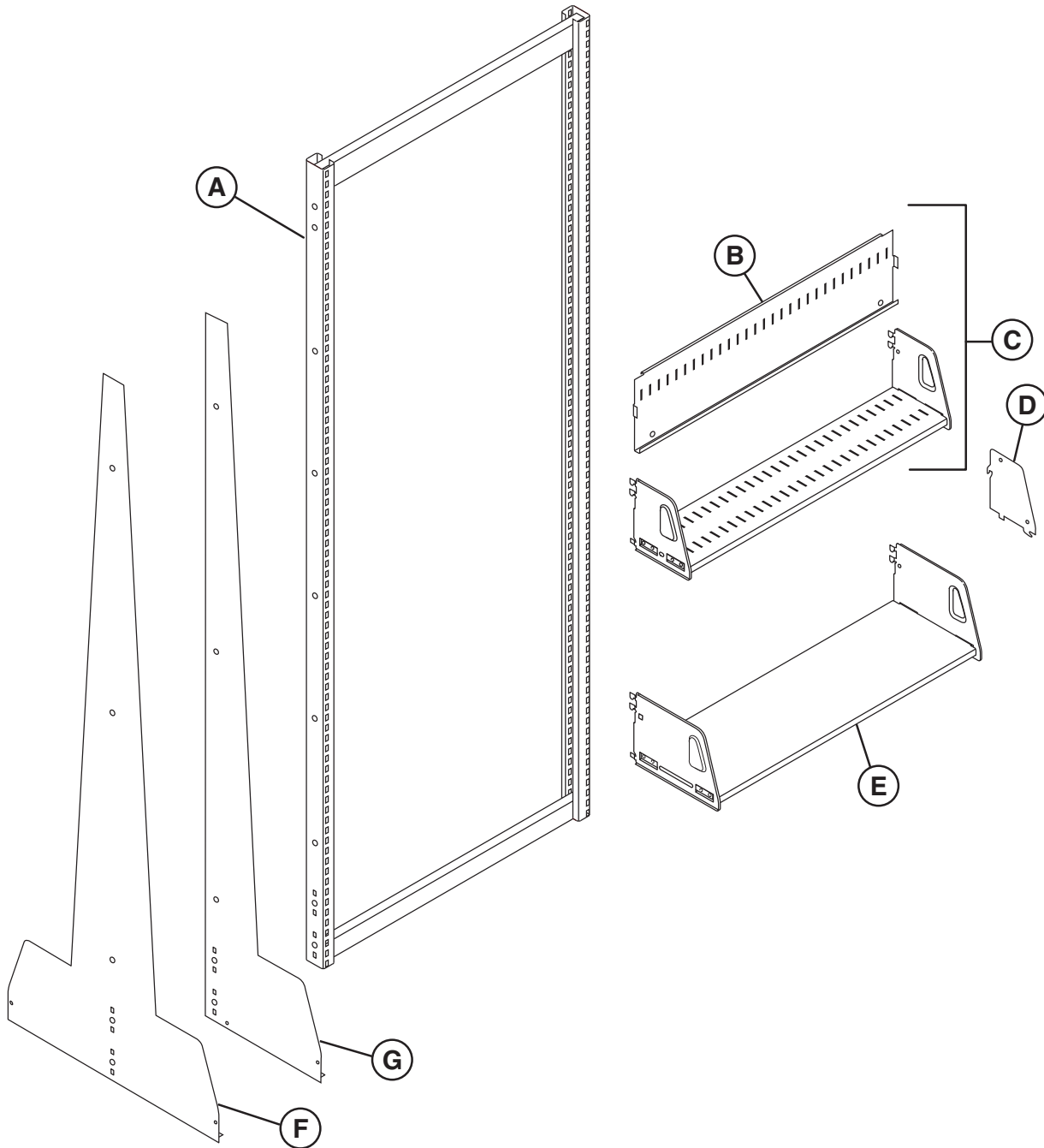

NOTE:

- Variable catalog number designators h = frame height, w = frame width, d = shelf depth
- Catalog number designators L = left, R = Right

DESCRIPTION	CATALOG NO.
A—WELDED FRAME	CFW-hw
B—SLOTTED BACKSTOP	CSBS-w
C—SLOTTED ADJUSTABLE SHELF <i>(Includes backstop)</i>	CSSB-wd
D—DIVIDER	CFD-d
E—PLAIN ADJUSTABLE SHELF	CSPB-wd
F—GUSSETED BASE SUPPORT - DOUBLE FACE	CDBG-d
G—GUSSETED BASE SUPPORT - SINGLE FACE	CSBG-dL or -dR

Major Components Identification / Static

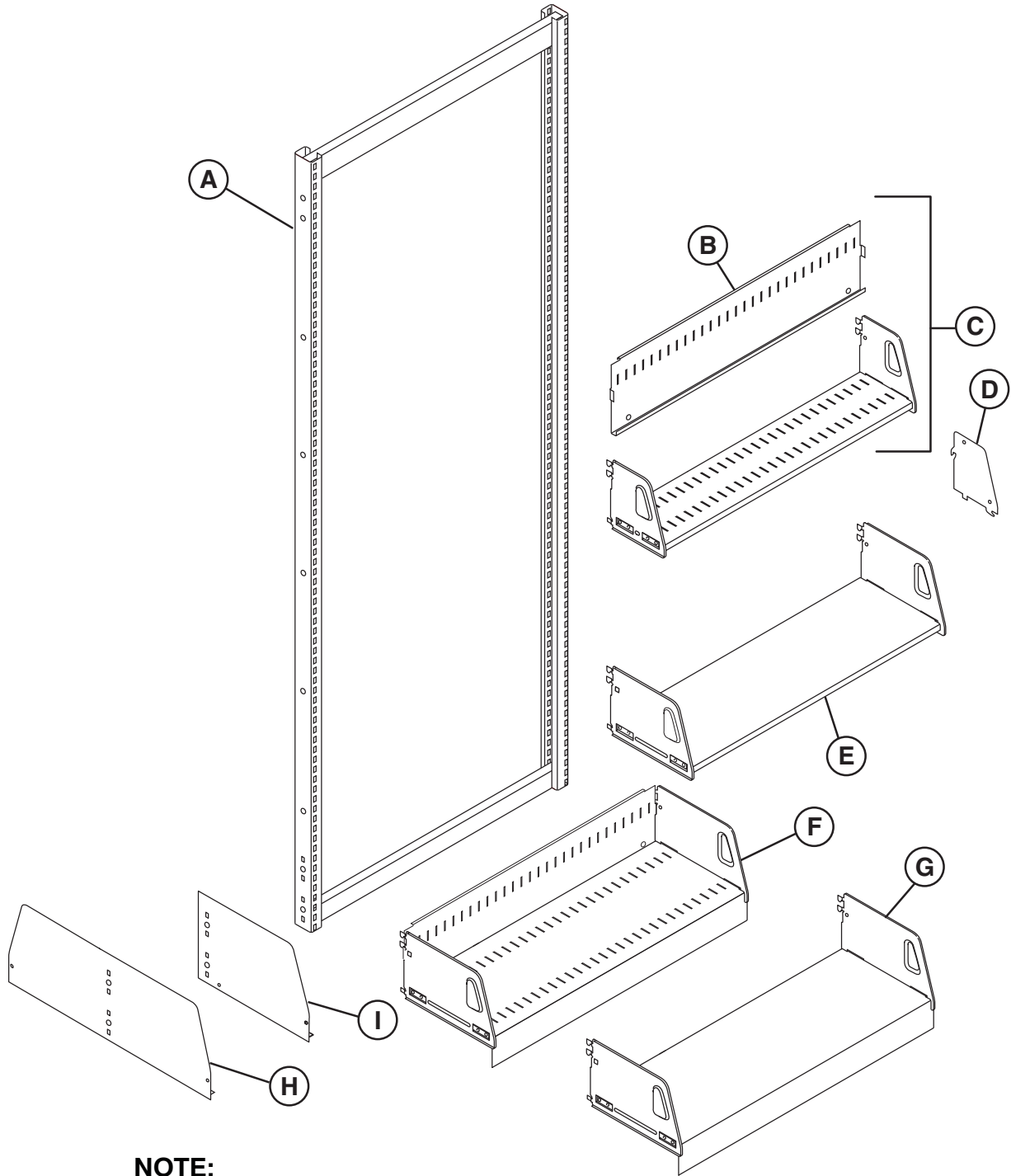

NOTE:

- Variable catalog number designators h = frame height, w = frame width, d = shelf depth
- Catalog number designators L = left, R = Right

DESCRIPTION	CATALOG NO.
A—WELDED FRAME	CWF-hw
B—SLOTTED BACKSTOP	CSBS-w
C—SLOTTED ADJUSTABLE SHELF (Includes backstop)	CSSB-wd
D—DIVIDER	CFD-d
E—PLAIN ADJUSTABLE SHELF	CSPB-wd
F—SLOTTED BASE SHELF	CBSSB-wd
G—PLAIN BASE SHELF	CBSPB-wd
H—BASE SUPPORT - DOUBLE FACE	CDB-d
I—BASE SUPPORT - SINGLE FACE	CSB-dL or -dR

Hardware Identification

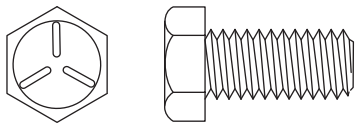

**3/8 - 16 X 3/4 Gr. 5 Hex
(Part No. 95021.08)**

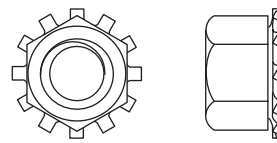

**3/8 - 16 Keps Nut
(Part No. 93015.08)**

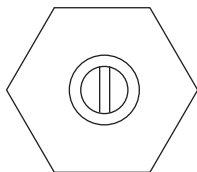

**3/8 - 16 Appliance Leveler
(Part No. 950071.001)**

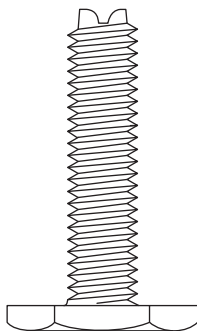

**3/8 - 16 Self Retaining Nut
(Part No. 93048.01)**

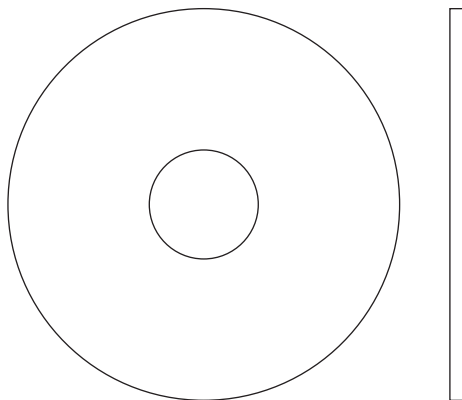

**9/16" I.D. X 2" O.D.
Spacer Washer**

STATIC UNIT CANTILEVER FRAME Bolt & Washer Requirements					
Upright Height	Base Foot Bolts ONLY	Mid Bolt(s) and Washers	Top Bolt and Washer	Total Bolts	Total Washers
42"	2	1	1	4	2
66"	2	1	1	4	2
78"	2	1	1	4	2
84"	2	2	1	5	3
90"	2	2	1	5	3

NOTE: Mobile units require five bolts through gusseted base support and one top bolt and washer.

Caution

All 3/8" hardware must be torque tightened to 25-30 ft. lbs. for safe installation.

Pre-Installation

Caution

Assembled shelving units must be level for proper stability. Leveler kits are optional and can be ordered.

Caution

Special applications may require shelving unit be floor-anchored or wall-mounted for adequate stability. Anchors are not provided as requirements vary. Wall attachment bracket kits (CWAB) are optional and can be ordered.

Before you begin installation:

1. Read through the installation procedure for your particular shelving unit.
2. Understand all CAUTION statements and apply them to your installation.
3. Make sure your shelving system will fit within the desired location.
4. Plan to assemble the shelving system where it will be used. Once fully assembled, the unit may be difficult to move.
5. Have the necessary tools for assembling and leveling the unit.
(2-9/16" deep sockets) (2-3/8" drive ratchet wrench)
(leveling devise) static only
(screwdriver)

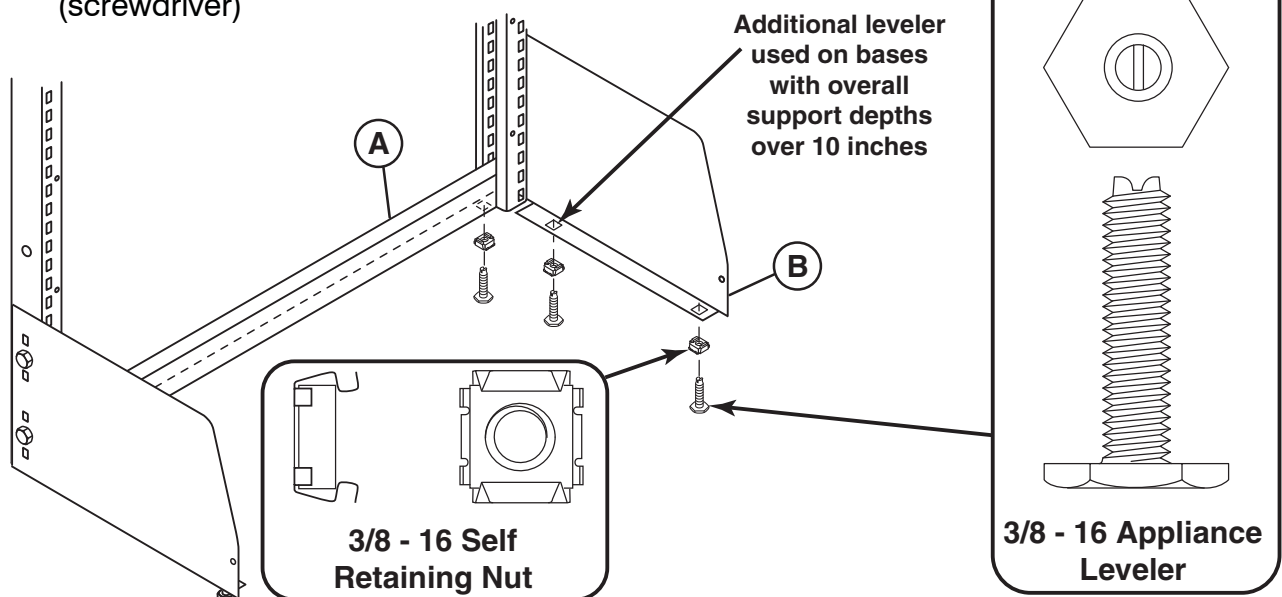

If optional leveler kit is used, it is recommended the levelers be installed prior to assembling the shelving units. Levelers are installed as follows:

1. Install self retaining nut in each square hole in bottom frame channel **(A)** and base supports **(B)** as shown.
2. Fully thread the appliance levelers into the self retaining nuts.
3. Assemble the frames and base supports per the installation instructions.
4. Before assembling the base shelf, make sure the shelving unit is in the exact location it will be used. Use a flathead screwdriver to adjust the levelers so they contact the floor surface.
5. Check the unit for proper level using a leveling device.
6. Using a flathead screwdriver, adjust the slotted leveler bolts up or down until unit is level.

Installation / Single Face Mobile Units



Caution

Anchoring the shelving unit to the mobile carriage is mandatory!

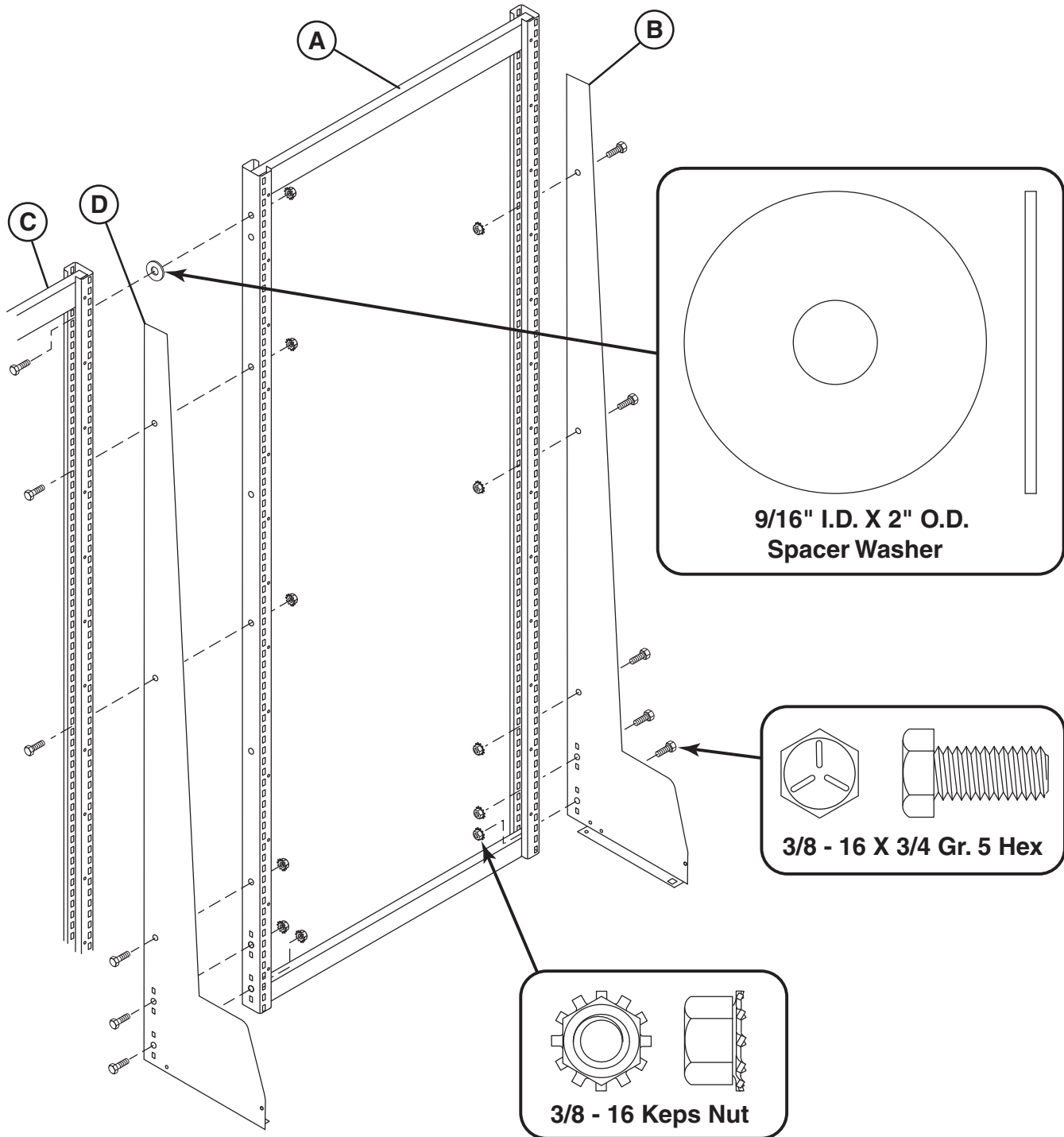

Installation / Single Face Mobile Units

NOTE: If your shelving system will have multiple frame sections, begin assembly at one of the end sections.

1. Stand frame end section **(A)** in upright position.
2. Attach **RIGHT** side base support **(B)** to frame as shown using five hex bolts and keps nuts.
3. Stand next frame section **(C)** upright beside first section.
4. Place **LEFT** side base support **(D)** between frame sections **(A and C)** and align mounting holes.
5. Assemble frames as shown using five hex bolts installed through frame **(C)**, base support **(D)**, and frame **(A)**. Do not fully tighten the keps nuts.
6. Install one spacer washer between top holes in frames and secure with hex bolt and keps nut as shown.
7. Torque tighten all hardware to 25 - 30 ft. lbs.
8. Repeat Steps 3 - 7 for each additional frame section to be installed.
9. Install **adjustable** shelves as desired on **FRONT** faces of frames only. See *Installation/Adjustable Shelves*.

Installation / Double Face Mobile Units



Caution

Anchoring the shelving unit to the mobile carriage is mandatory!

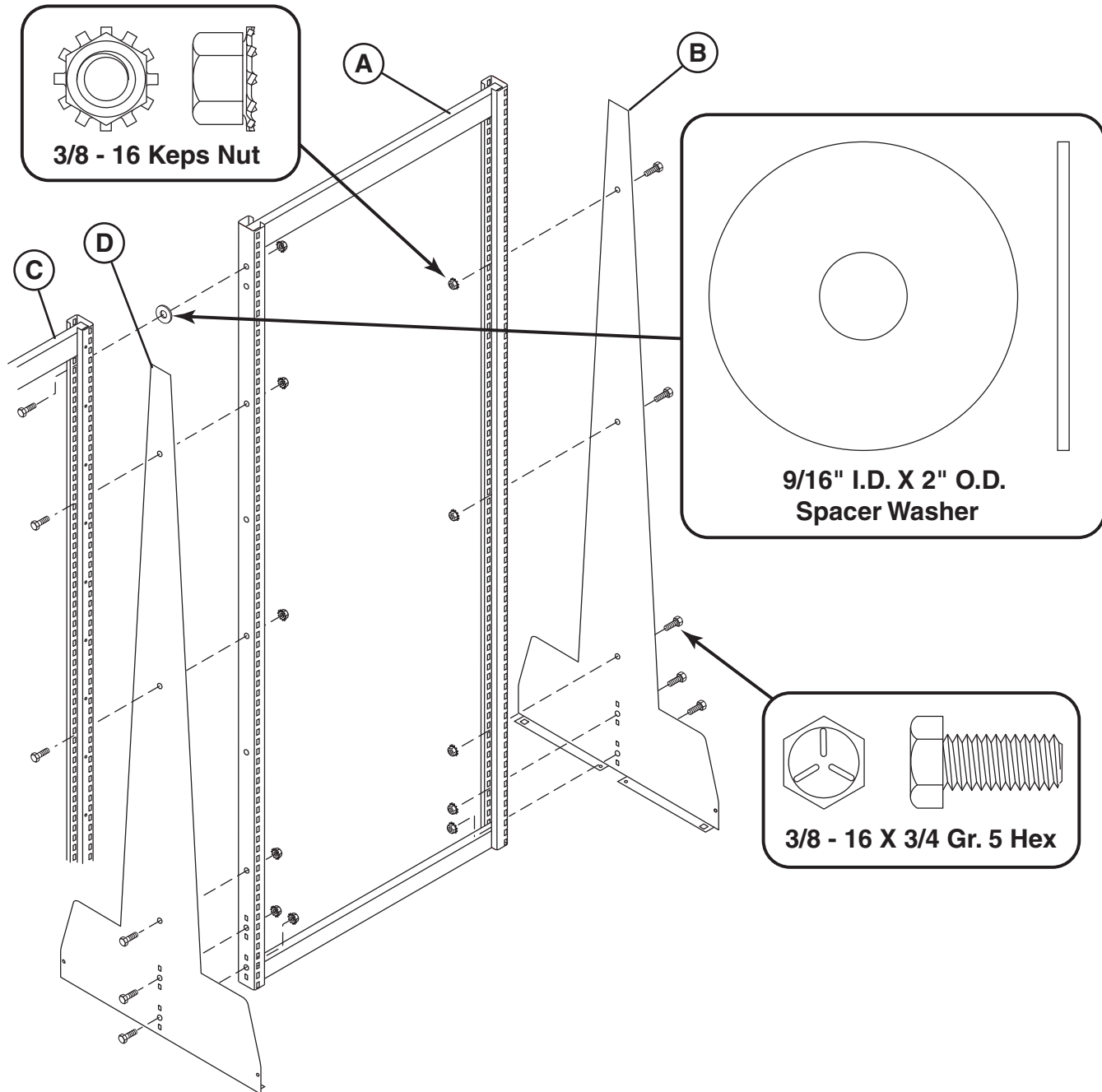

Installation / Double Face Mobile Units

NOTE: If your shelving system will have multiple frame sections, begin assembly at one of the end sections.

1. Stand frame end section **(A)** in upright position.
2. Attach base support **(B)** to frame as shown using five hex bolts and keps nuts.
3. Stand next frame section **(C)** upright beside first section.
4. Place base support **(D)** between frame sections **(A and C)** and align mounting holes.
5. Assemble frames as shown using five hex bolts installed through frame **(C)**, base support **(D)**, and frame **(A)**. Do not fully tighten the keps nuts.
6. Install one spacer washer between top holes in frames and secure with hex bolt and keps nut as shown.
7. Torque tighten all hardware to 25 - 30 ft. lbs.
8. Repeat Steps 3 - 7 for each additional frame section to be installed.
9. Install **adjustable** shelves as desired on FRONT and REAR faces of frames. See *Installation/Adjustable Shelves*.

Installation / Single Face Static Units

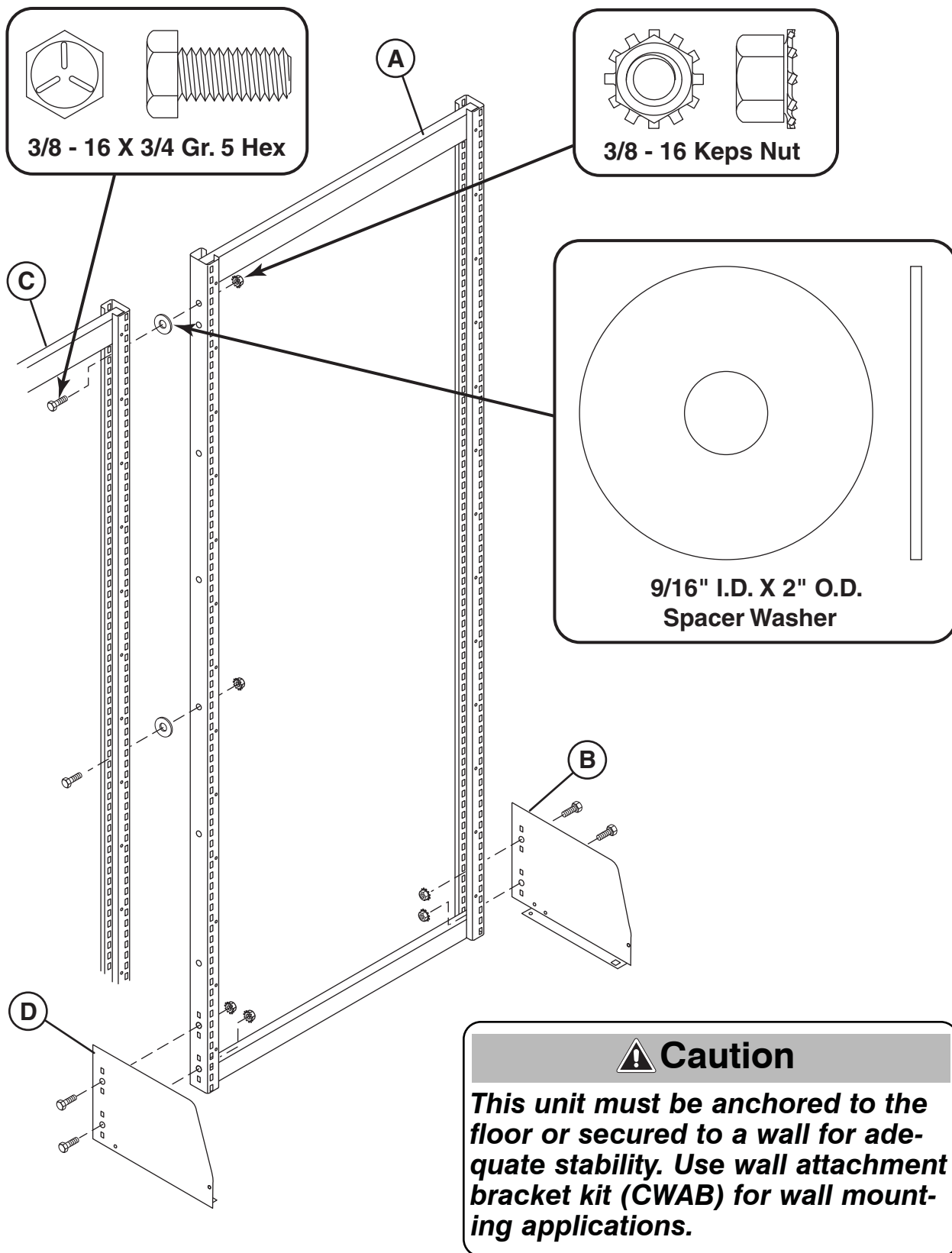

Installation / Single Face Static Units

NOTE: If optional leveler kit is used, it is recommended the levelers be installed prior to Step 1.

NOTE: If your shelving system will have multiple frame sections, begin assembly at one of the end sections.

1. Stand frame end section **(A)** in upright position.
2. Attach **RIGHT** side base support **(B)** to frame as shown using two hex bolts and keps nuts.
3. Stand next frame section **(C)** upright beside first section.
4. Place **LEFT** side base support **(D)** between frame sections **(A and C)** and align mounting holes.
5. Install two hex bolts through frame **(C)**, base support **(D)**, and frame **(A)**. Do not fully tighten the keps nuts.
6. Install one spacer washer between top holes in frames using hex bolt and keps nut as shown. Do not fully tighten the keps nut.
7. **42" - 78" high frames only:** Install one spacer washer between the holes at the **mid-way** point of the frames using hex bolt and keps nut as shown.
84" - 90" high frames only: Install one spacer washer between the holes **1/4-way** down from top of frame using hex bolt and keps nut.
Install one spacer washer between the holes **3/4-way** down from top of frame using hex bolt and keps nut.
8. Torque tighten all hardware to 25 - 30 ft. lbs.
9. Level the shelving unit.
10. Repeat Steps 3 - 9 for each additional frame section to be installed.
11. Install **base** shelves on **FRONT** faces of frames. See *Installation/Base Shelves*.
12. Install **adjustable** shelves as desired on **FRONT** faces of frames only. See *Installation/Adjustable Shelves*.

Installation / Double Face Static Units

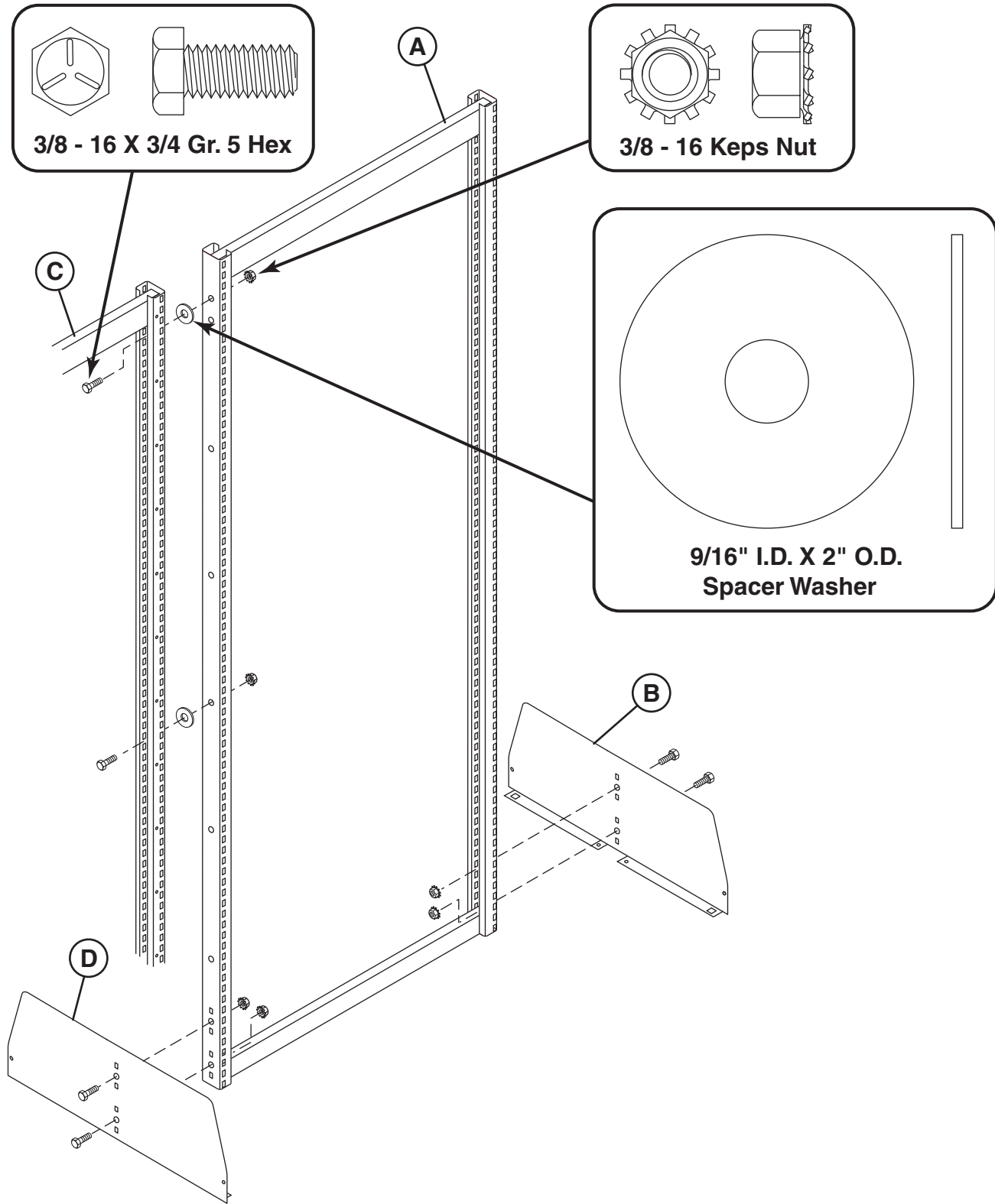

Installation / Double Face Static Units

NOTE: If optional leveler kit is used, it is recommended the levelers be installed prior to Step 1.

NOTE: If your shelving system will have multiple frame sections, begin assembly at one of the end sections.

1. Stand frame end section **(A)** in upright position.
2. Attach **RIGHT** side base support **(B)** to frame as shown using two hex bolts and keps nuts.
3. Stand next frame section **(C)** upright beside first section.
4. Place **LEFT** side base support **(D)** between frame sections **(A and C)** and align mounting holes.
5. Install two hex bolts through frame **(C)**, base support **(D)**, and frame **(A)**. Do not fully tighten the keps nuts.
6. Install one spacer washer between top holes in frames using hex bolt and keps nut as shown. Do not fully tighten the keps nut.
7. **42" - 78" high frames only:** Install one spacer washer between the holes at the **mid-way** point of the frames using hex bolt and keps nut as shown.
84" - 90" high frames only: Install one spacer washer between the holes **1/4-way** down from top of frame using hex bolt and keps nut.
Install one spacer washer between the holes **3/4-way** down from top of frame using hex bolt and keps nut.
8. Torque tighten all hardware to 25 - 30 ft. lbs.
9. Level the shelving unit.
10. Repeat Steps 3 - 8 for each additional frame section to be installed.
11. Install **base** shelves on **FRONT** and **REAR** faces of frames. See *Installation/Base Shelves*.
12. Install **adjustable** shelves as desired on either side of frames. See *Installation/Adjustable Shelves*.

Installation / Adjustable Shelves

Plain Adjustable Shelves

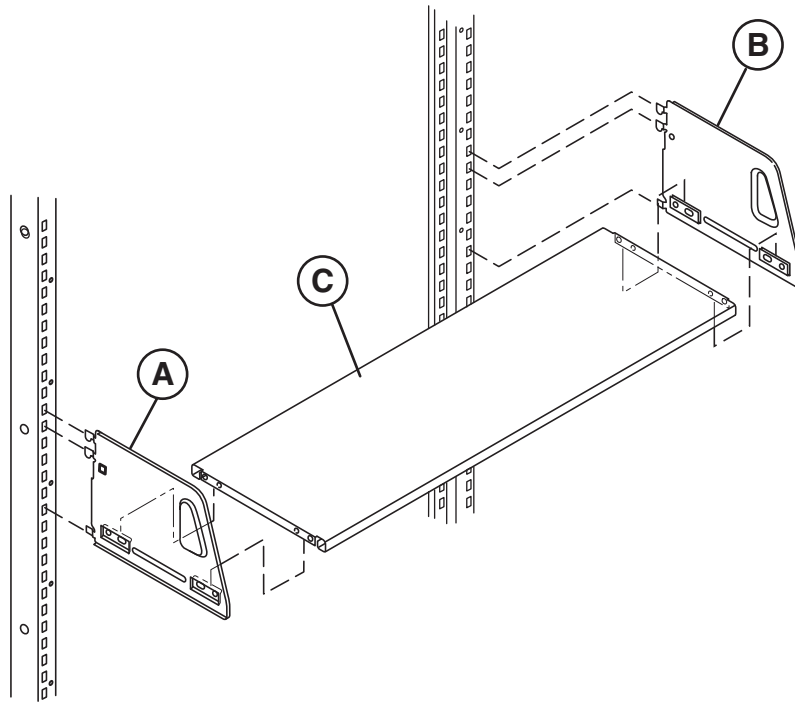

1. Hang LEFT end bracket (A) and RIGHT end bracket (B) onto frame upright at equal elevations as shown.

NOTE: End brackets are distinguished by a stamped “R” (RIGHT) or “L” (LEFT) on their surface.

2. Place shelf (C) between end brackets so shelf edges are inside the slotted tabs of the end brackets.
3. Apply downward force to drive shelf into place.

Installation / Adjustable Shelves

Slotted Adjustable Shelves with Dividers

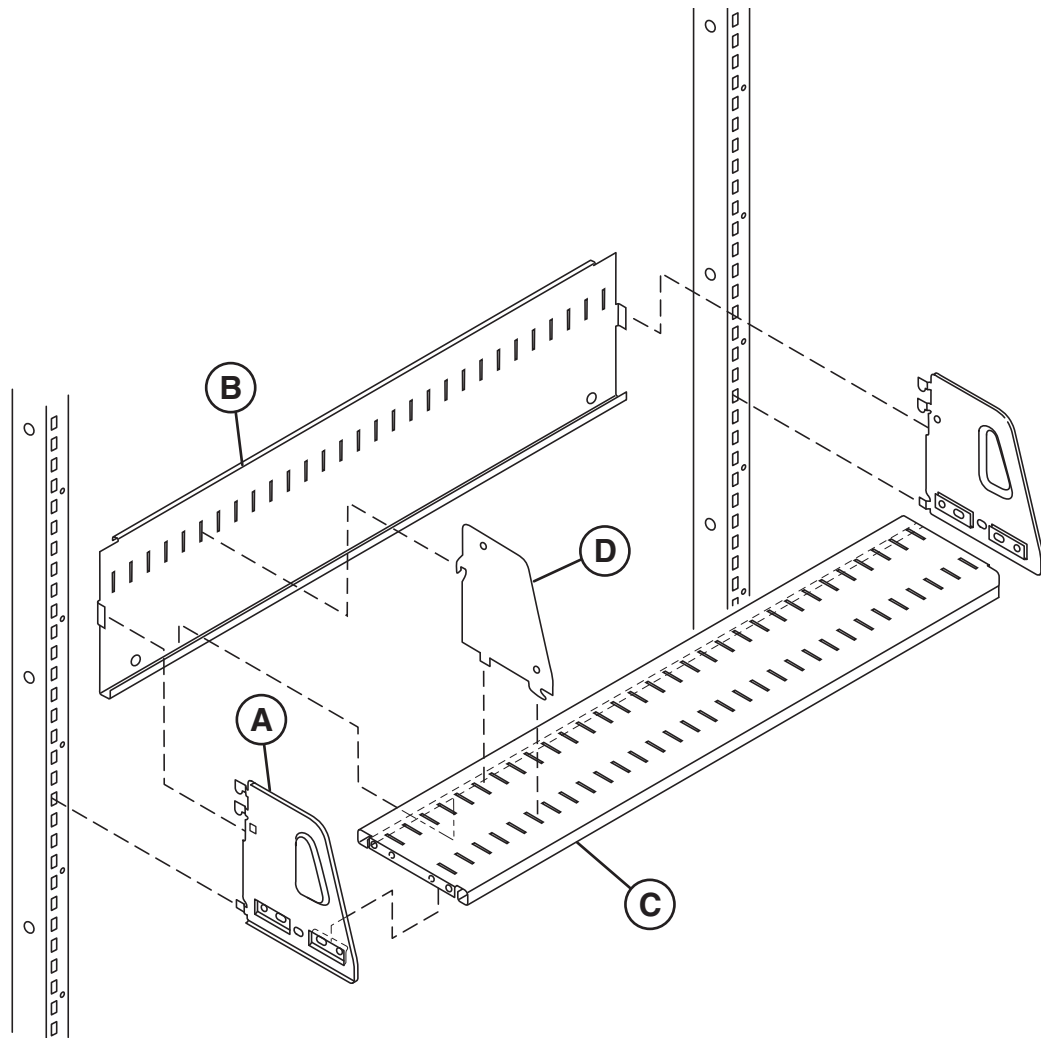

1. Hook one end bracket **(A)** over tab on matching side of backstop **(B)**.

NOTE: End brackets are distinguished by a stamped “R” (RIGHT) or “L” (LEFT) on their surface.

2. Hook the two pieces **(A and B)** into the frame upright at desired elevation so one side of backstop is secure.
3. Hook opposite side end bracket over tab on other end of backstop and hook this end into frame upright at equal elevation. Backstop and end brackets are now installed.
4. Place shelf **(C)** between end brackets so back edge of shelf hooks over bottom lip of backstop and sides of shelf are inside the slotted tabs of the end brackets.
5. Apply downward force to drive shelf into place.
6. Install dividers **(D)** as shown.

Installation / Base Shelves

Plain Base Shelves

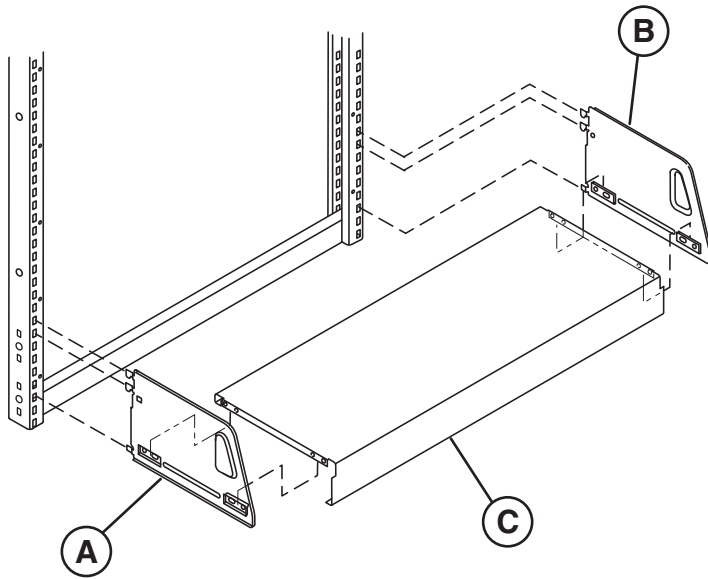

1. Hang LEFT end bracket **(A)** and RIGHT end bracket **(B)** onto frame upright, leaving open the bottom two slots in the frame channel.

NOTE: End brackets are distinguished by a stamped “R” (RIGHT) or “L” (LEFT) on their surface.

2. Place base shelf **(C)** between end brackets so shelf edges are inside the slotted tabs of the end brackets.
3. Apply downward force to drive base shelf into place.

Slotted Base Shelves with Dividers

1. Hook one end bracket **(A or B)** over tab on matching side of backstop **(C)**.
5. Apply downward force to drive base shelf into place.
6. Install dividers **(E)** as shown.

NOTE: End brackets are distinguished by a stamped “R” (RIGHT) or “L” (LEFT) on their surface.

2. Hook the two pieces (bracket and backstop) into the frame upright, leaving open the bottom two slots in the frame channel.
3. Hook opposite side end bracket over tab on other end of backstop and hook this end into frame upright at equal elevation. Backstop and end brackets are now installed.
4. Place base shelf **(D)** between end brackets so back edge of shelf hooks over bottom lip of backstop and sides of shelf are inside the slotted tabs of the end brackets.

