

Foodservice Equipment • Material Handling, Healthcare & Cleanroom Equipment • Retail Display

Roll Bag Dispenser



Item #:	_____
Model #:	_____
Project #:	_____
SIS #:	_____

Optional Accessories	Model #	Qty.
Outrigger base extension		



roll bag dispenser

- An effective means of dispensing products on rolls or spools.
- An easy way to establish protocol by color of cleanroom waste avoiding inadvertent mixing of non-compatible items.
- Standard roll bag dispenser unit consists of two 14" x 48" (356 x 1219mm) wire shelves, eight removable dispenser bars, one channel frame, and four 74" (1880mm) posts with 30" (762mm) outrigger feet for stability.
- Dispensing bars are adjustable on 1" (25mm) increments.
- Available in stainless steel or chrome finish. Custom sizes and configurations available.
- Allows significant inventory to be stored at the point of use.

Roll Bag Dispenser

Design & Construction Features

- Two 14" x 48" (356 x 1219mm) wire shelves.
- Eight removable dispenser bars.
- Four 74" (1880mm) posts with 30" (762mm) outrigger feet for stability.
- One 3-sided channel frame.
- Dispensing bars adjustable on 1" (25mm) increments.
- Available in stainless steel or chrome finish.
- Custom sizes and configurations available.

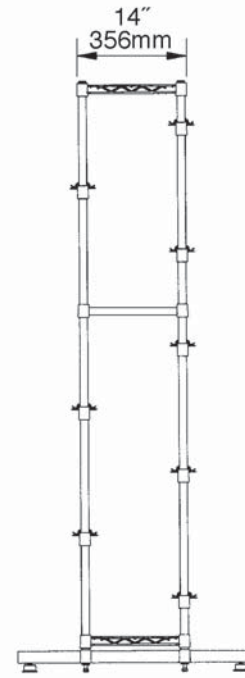
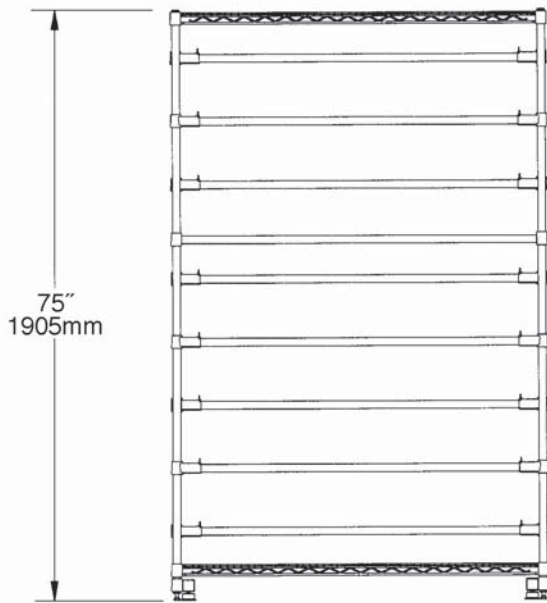
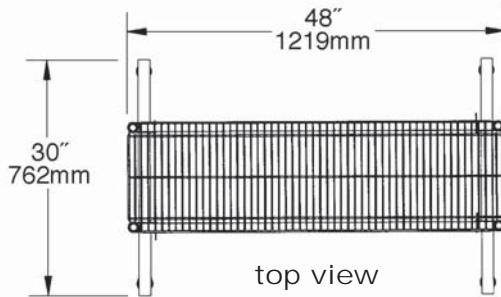

width x length		chrome model #	stainless steel model #
in.	mm		
14" x 48"	356 x 1219	BD1448C	BD1448S

Outrigger Base Extension for Roll Bag Dispenser

front-to-back		chrome model #	stainless steel model #
in.	mm		
30"	762	C30-PBB	S30-PBB